

V600 Series 3 1/4" Frame Depth Project-Out

V600 SERIES PROJECT-OUT

FEATURES

- ◇ **Commercial Framing System**
 - 3 1/4" main frame
 - Architectural grade uPVC frame
- ◇ **Enhanced Design**
 - Mitered and welded corners
- ◇ **Glazing**
 - 1" insulating glass
- ◇ **Hardware**
 - Multi-point locking system
- ◇ **Screen**
 - Wicket Screen
- ◇ **Colors**
 - White uPVC vinyl (interior/exterior)

BENEFITS

- ◇ Perfect uPVC product for commercial projects

PERFORMANCE

- ◇ Structural & Thermal (test reports or thermal simulations available upon request)

Model	Project-Out
NAFS Rating	AW-75*
Structural Load P.S.F.	
Air infiltration	<0.10*
Water (No Penetration) P.S.F.	up to 15*
U-Value (ranges based on multiple Low-E/Argon combinations)	0.19-0.35*
SHGC	
CR	65*
STC	32*
OITC	42*

* All NAFS Certifications, Thermal Testing and Acoustic Testing data shown are projected as of 7-23-2024.

OPTIONS

- ◇ **Available Configurations**
 - Project-out
- ◇ **Muntin Choices**
 - Internal or simulated divided lites available
- ◇ **Limited Travel Hardware**
- ◇ **Screen**
 - Extruded aluminum screen frame with BetterVue™ mesh with WaterShed® technology
 - Extruded aluminum screen frame with aluminum wire mesh
 - Extruded aluminum screen frame with sunscreen mesh
 - Extruded aluminum screen frame with stainless steel 0.009" thickness mesh
- ◇ **Glazing**
 - 1 3/8" insulating glass
 - Multiple Low-E and argon glazing choices
 - Triple glazing (Energy TG)
 - Capillary tubes
 - Wide variety of glazing, tinting and thickness options
- ◇ **Panning & Trim Choices**
 - Wide variety of panning, receptor and trim available
- ◇ **Mulling**
 - Wide variety of structural mulls
- ◇ **Colors**
 - High-performance Textured Black laminate (interior/exterior)
 - High-performance Textured Black laminate (exterior only)
 - High-performance Textured Dark Bronze laminate (exterior only)

Our products are tested to the standards of and certified by some of the foremost organizations in the fenestration industry.



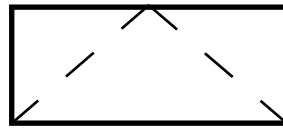

V600 Series 3 1/4" Frame Depth Project-Out

V600 PROJECT-OUT

This document contains confidential and proprietary information intended for the private use of Quaker.
 © 2016 Quaker Window Products Co., INC. All rights reserved.
 Quaker reserves the right to change any/all designs without notice. Due to periodic re-certification requirements, result shown may vary.

① HORIZONTAL
CROSS SECTION

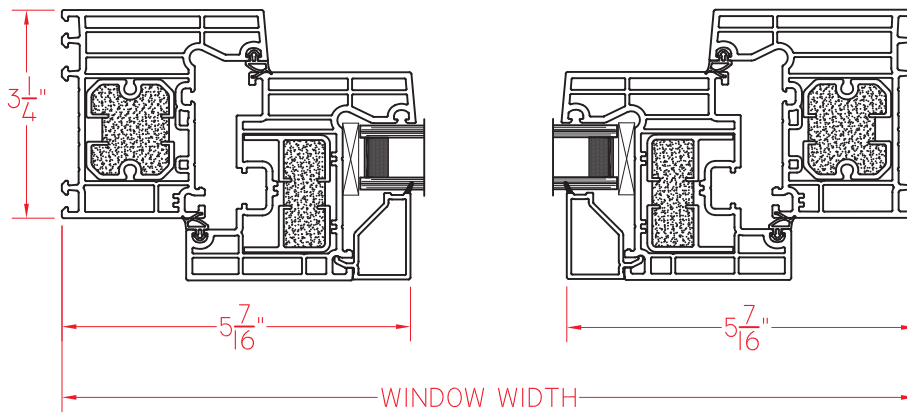

Ⓐ VERTICAL
CROSS SECTION

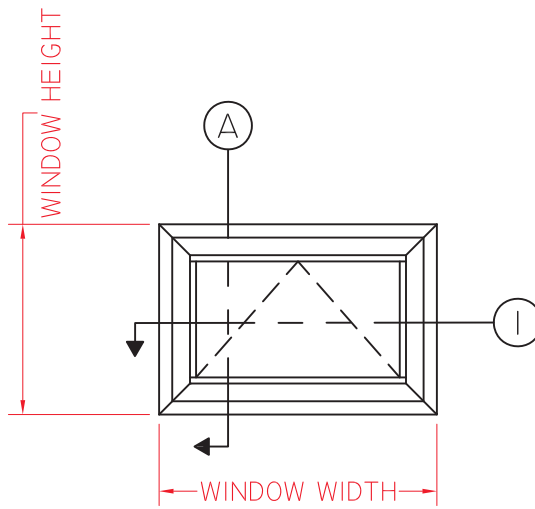
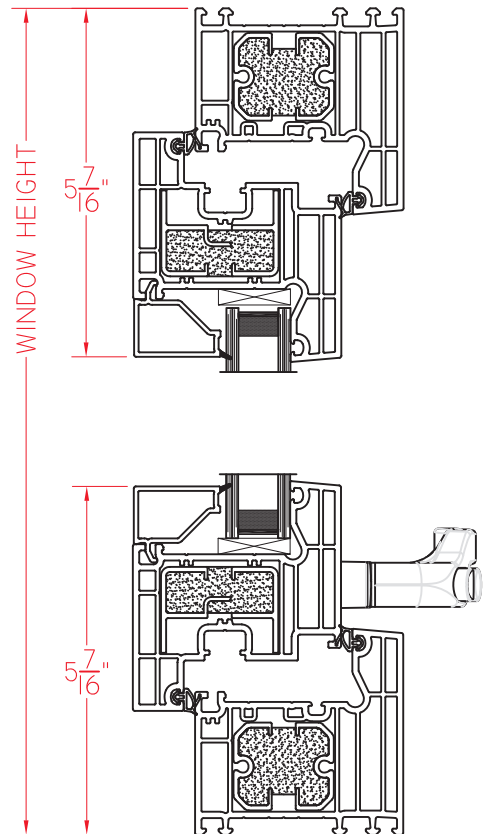

ELEVATION SCALE 3/4" = 1'-0"

SCALE: 4" = 1'-0"

Our products are tested to the standards of and certified by some of the foremost organizations in the fenestration industry.



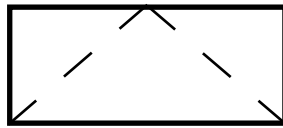

V600 Series
3 1/4" Frame Depth
Project-Out

V600 SERIES RECEPTOR SYSTEM

This document contains confidential and proprietary information intended for the private use of Quaker.
 © 2016 Quaker Window Products Co., INC. All rights reserved.
 Quaker reserves the right to change any/all designs without notice. Due to periodic re-certification requirements, result shown may vary.

① HORIZONTAL CROSS SECTION

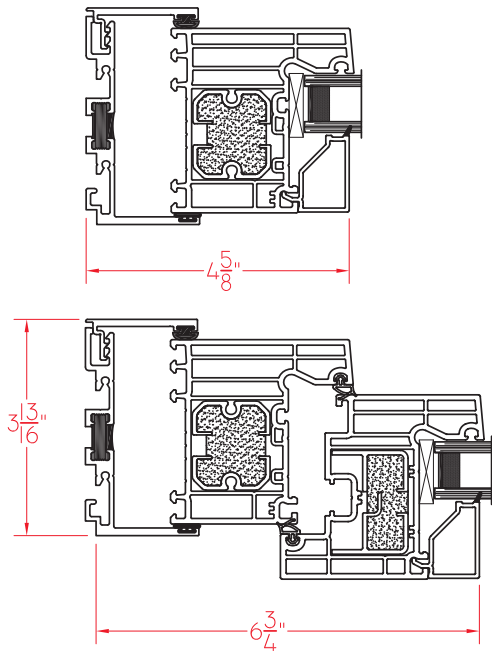

Ⓐ VERTICAL CROSS SECTION

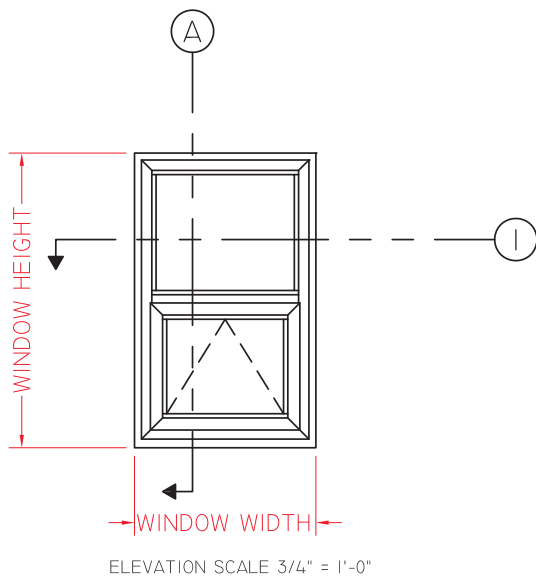
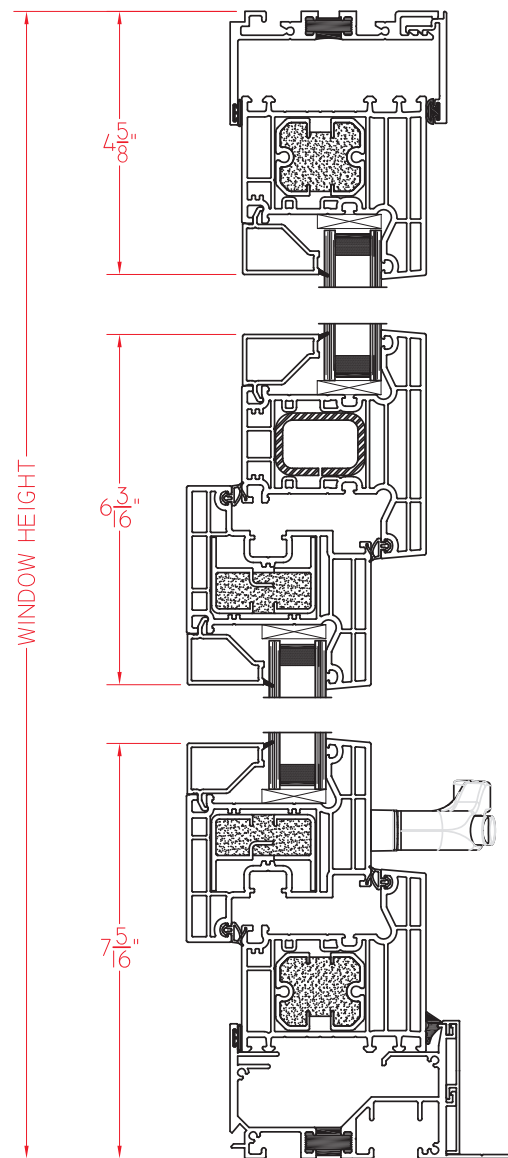

Our products are tested to the standards of and certified by some of the foremost organizations in the fenestration industry.



SCALE: 4" = 1'-0"

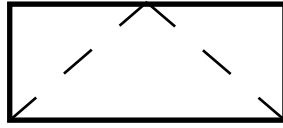

V600 Series 3 1/4" Frame Depth Project-Out

V600 SERIES T-MULL

This document contains confidential and proprietary information intended for the private use of Quaker.
© 2016 Quaker Window Products Co., INC. All rights reserved.
Quaker reserves the right to change any/all designs without notice. Due to periodic re-certification requirements, result shown may vary.

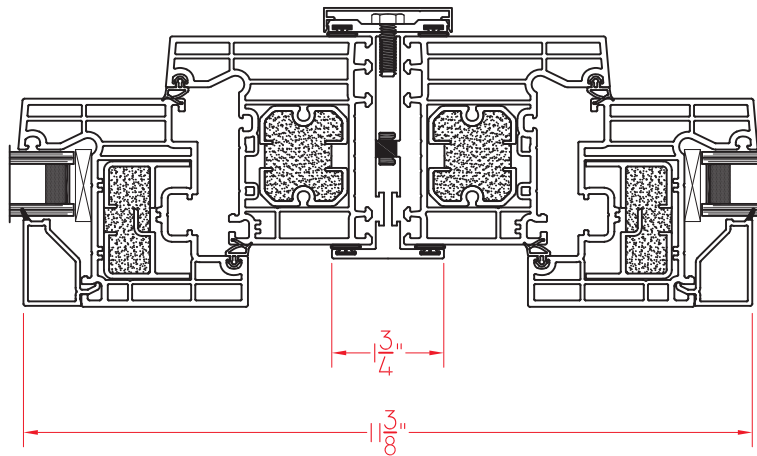
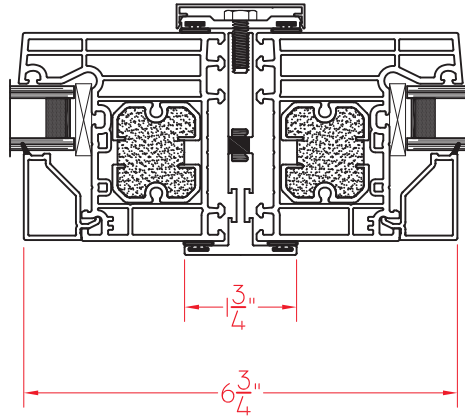

SCALE: 4" = 1'-0"

Our products are tested to the standards of and certified by some of the foremost organizations in the fenestration industry.



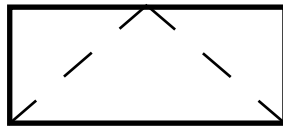

V600 Series
3 1/4" Frame Depth
Project-Out

V600 SERIES STRAP ANCHOR

This document contains confidential and proprietary information intended for the private use of Quaker.
 © 2016 Quaker Window Products Co., INC. All rights reserved.
 Quaker reserves the right to change any/all designs without notice. Due to periodic re-certification requirements, result shown may vary.

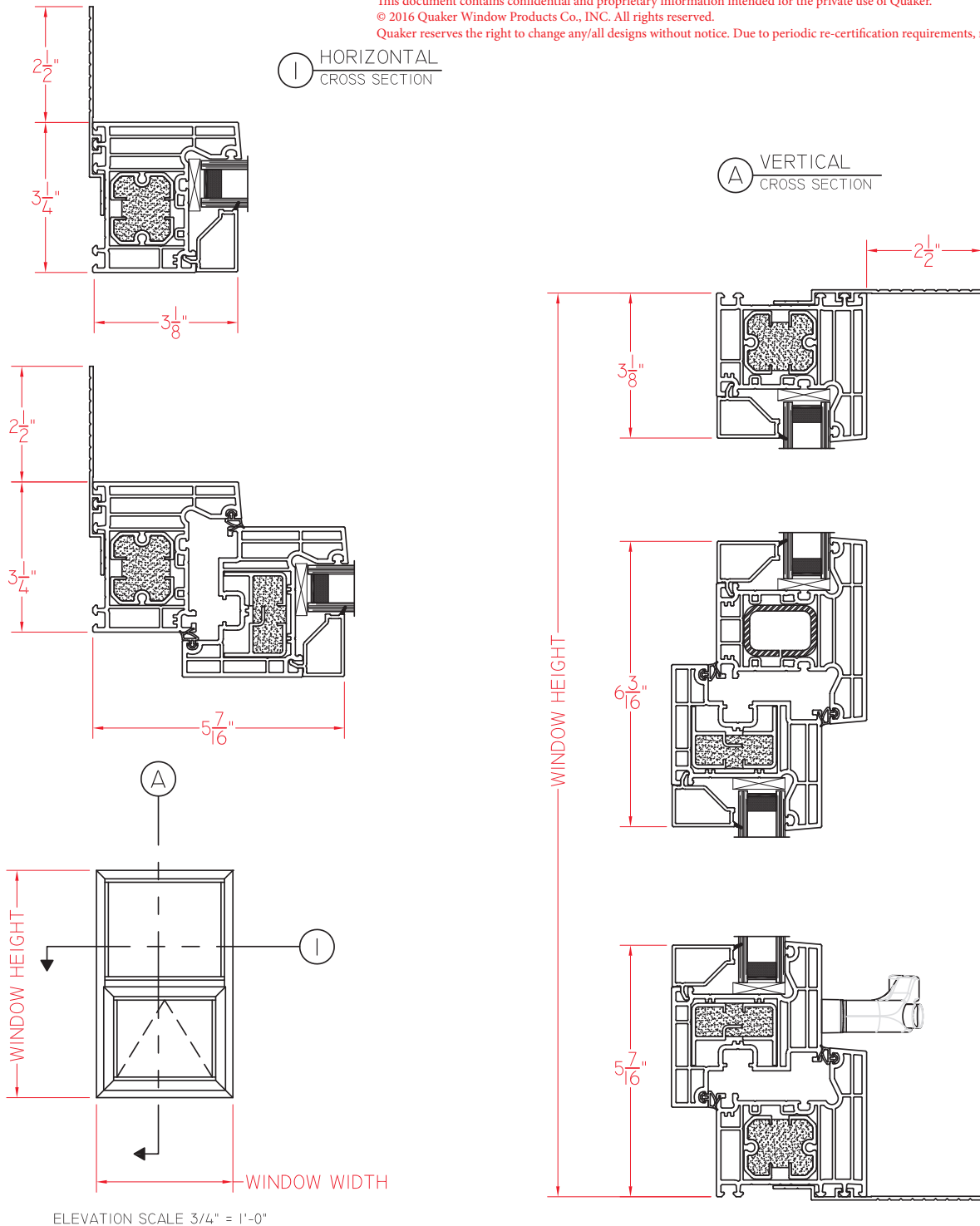

Our products are tested to the standards of and certified by some of the foremost organizations in the fenestration industry.



SCALE: 4" = 1'-0"